

CLASS 150 CAST BRONZE SCREWD END GATE VALVES

INSIED SCREW,RISING STEM,SCREWED BONNET

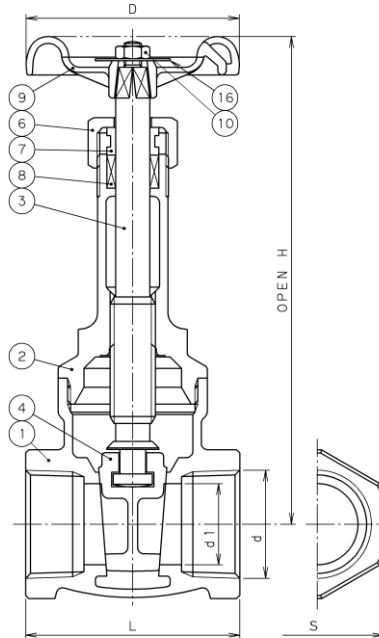

Materials

No.	Name of parts	ASTM Specifications		
1	BODY	CAST BRONZE	B62-C83600	
2	BONNET	CAST BRONZE	B62-C83600	
3	STEM	CAST BRONZE	B62-C83600	
4	DISC	CAST BRONZE	B62-C83600	
6	PACKING NUT	FORGED BASS	B283-C37700	
7	GLAND	BRASS ROD	B16	
8	GLAND PACKING	ARAMID FIBERS GRAPHITE		
9	HAND WHEEL	ALUMINUM DIE-CAST	B85	
10	WHEEL NUT	BRASS ROD	B16	
16	NAME PLATE	ALUMINUM		

Dimensions

Mark	Size	1/2	3/4	1	1 1/4	1 1/2	2
d	NPT 1/2	NPT 3/4	NPT 1	NPT 1 1/4	NPT 1 1/2	NPT 2	
	mm.	15	20	25	32	40	50
G	mm.	137	157	180	216	257	296
H	mm.	51	56	66	68	74	84
L	mm.	55	70	70	80	90	100
D	mm.	28	34	41	52	57	70
Weight	kgs.	0.42	0.64	0.94	1.66	1.83	2.72

Working Pressures

Working pressures Non-Shock	
Saturated steam pressure	Water,Oil,Gas
1.03MPa	2.07MPa
150psi	300psi

*Design and materials are subject to change without notice.