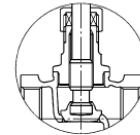
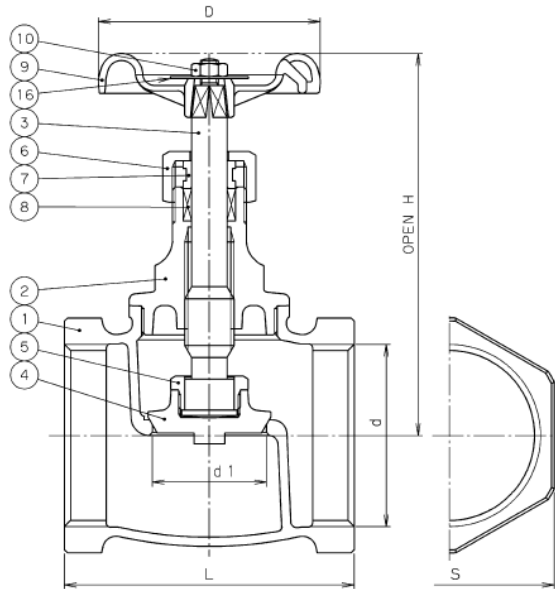

FIG. No. 210A

CLASS 100 CAST BRONZE SCREWED END GLOBE VALVE

SCREWED BONNET, INSIDE SCREW



SIZE 1/4 to 1 1/4



1/4
100

SIZE 1/4



100-1/2

SIZE 3/8 & 1/2



100-1

SIZE 3/4 to 3
BODY MARKING

Materials

No	Name of parts	Specifications	
1	BODY	CAC	Cast Bronze
2	BONNET	C3771BE	
3	STEM	Special Brass *1	
4	DISK	CAC	Cast Bronze
5	LOCK NUT	C3771BD	SIZE 11/2 to 3
6	PACKING NUT	C3771BE	
7	GLAND	C3604BD	SIZE 11/2 to 3
8	GLAND PACKING	Non-asbestos packing	
9	HAND WHEEL	ADC12	
10	WHEEL NUT	SS400	ZINC PLATED
16	NAME PLATE	A1050P	

*1 Dezincification-Resistant Copper Alloy

Working Pressures

Service conditions
16bar at 100°C, 7bar at 170°C

Dimensions

Mark	SIZE	SIZE									
		1/4	3/8	1/2	3/4	1	1 1/4	1 1/2	2	2 1/2	3
d		Rc1/4	Rc3/8	Rc1/2	Rc3/4	Rc1	Rc1 1/4	Rc1 1/2	Rc2	Rc2 1/2	Rc3
d1	mm	12.5	12.5	12.5	13.5	19.0	24.0	32.0	37.0	48.5.0	60.0
H	mm	67	68	69	81	95	104	127	147	178	200
L	mm	40	42	48	53	63	73	81	94	115	131
D	mm	48	48	55	63	70	80	90	100	110	125
S	mm	19	23	27	33	41	50	56	68	86	100
Weight	kg	0.18	0.19	0.23	0.27	0.45	0.63	0.96	1.38	2.5	3.33

*Design and materials are subject to change without notice.